

HIGHBAY LIGHTING

Introducing the APOLLO



The **APOLLO** is a decorative and stylish surface or suspended LED HIGHBAY luminaire with a wide range of light distribution and output options for retail, storage and industrial applications.



Consult SA (PTY) LTD



SABS
ISO 9001

APOLLO



Product Benefits

- Attractive and efficient
- Low maintenance
- Built-in LED driver
- Easy installation
- SABS approved control gear
- SANS-IEC 60598 safety compliance and mark

Product Features

- Unsurpassed efficacy due to latest generation LED modules
- Highly efficient modular optics
- Low glare
- Variable output possible by setting different drive currents
- Options include emergency, DALI dimmable, LI-Connect Bluetooth mesh control and additional surge protection
- Long life
- Stainless steel mounting clips allow simple installation
- LED life L₈₀B₁₀ - 50 000 hours
- Driver life F₁₀ - 100 000 hours
- Supply = 220-240V 50-60Hz PF>0.95
- Surge current (flicker) < 5%
- 5 year guarantee



 **135 lm/W**

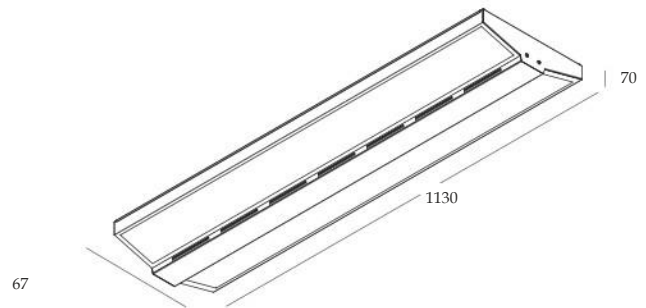
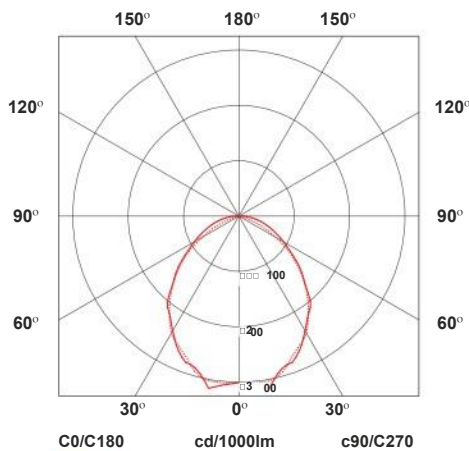

Efficacy Rating

-  **PREMIUM RANGE** >140 lm/W
-  **MID RANGE** 120 - 140 lm/W
-  **ECO RANGE** 100 - 120 lm/W

Luminaire Wattage	Luminaire Output (Lumens)	Colour Temperature	Efficacy lm/W	Ra (CRI)	Reference Code
1200mm module					
88W (350mA)	11 880	4000K	135	>85	LLC-APO-88W-2R12
116W (550mA)	14 730	4000K	127	>85	LLC-APO-116W-2R12
160W (750mA)	19 200	4000K	120	>85	LLC-APO-160W-2R12



Consult SA (PTY) LTD

