

RECESSED LIGHTING

Introducing the **AZTEZ**



The **AZTEZ** is a semi-direct recessed luminaire with a formed opal diffuser. Ideal for offices, conference facilities, schools and shopping malls.



Consult SA (PTY) LTD



SABS
ISO 9001



Product Benefits

- Attractive and efficient
- Modern sleek design
- Low maintenance
- Built In LED driver
- Easy installation
- SABS approved driver
- SANS-IEC 60598 safety compliance and mark

Product Features

- Highly efficient back-lit formed opal diffuser
- Variable light output possible by adjusting LED drive current
- Options include DALI dimming, mesh control, tuneable white , emergency backup and HF sensors.
- Long life
- Available in 600x600 or 1200x600 ceiling format
- LED life L_{80B10} - 50 000 hours
- Driver life F₁₀ - 50 000 hours
- Supply - 220-240V 50-60Hz PF > 0.95
- Surge current (flicker) < 5%
- 5 year guarantee



133 lm/W

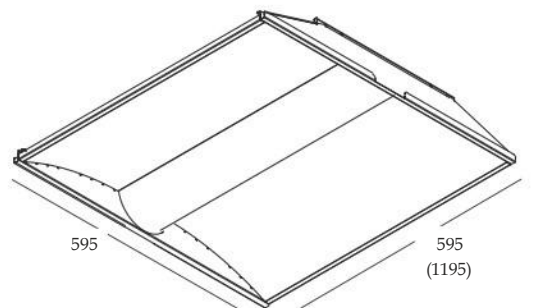
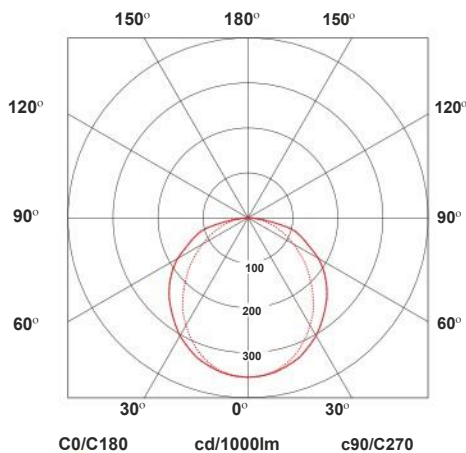

Efficacy Rating

- PREMIUM RANGE** >140 lm/W
- MID RANGE** 120 - 140 lm/W
- ECO RANGE** 100 - 120 lm/W

Luminaire Wattage	Luminaire Output (Lumens)	Colour Temperature	Efficacy lm/W	Ra (CRI)	Reference Code
600 x 600					
25W	3 400	4000K	136	>80	LLC-ATZ-25W-2R6
32W	4 200	4000K	131	>80	LLC-ATZ-32W-2R6
1200 x 600					
39W	5 370	4000K	138	>80	LLC-ATZ-39W-2R12
54W	7 250	4000K	134	>80	LLC-ATZ-54W-2R12

