

VANDAL-PROOF LIGHTING

Introducing the HULK



The **HULK** is a surface mounted vandal-proof luminaire for the illumination of prison cells and other vulnerable interior and exterior areas. The luminaire has a uniquely constructed patented 'sandwiched' burns test compliant diffuser with an impact resistance rating of IK16.



Consult SA (PTY) LTD



SABS
ISO 9001

HULK



Product Benefits

- Durable construction
- Low maintenance
- Built in LED drivers with nightlight
- Easy installation
- SABS approved driver
- SANS-IEC 60598 safety compliance and mark

Product Features

- LED Night-Light Optional
- High impact rating of IK16
- Powder coated mild steel or optional stainless steel body
- Variable light output possible by adjusting LED drive current
- Options include emergency, DALI dimmable, LI-Connect Bluetooth mesh control and additional surge protection
- Long life
- LED life L_{80B10} - 50 000 hours
- Driver life F_{10} - 100 000 hours
- Supply = 220-240V 50-60Hz PF>0.95
- Surge current (flicker) < 5%
- 5 year guarantee

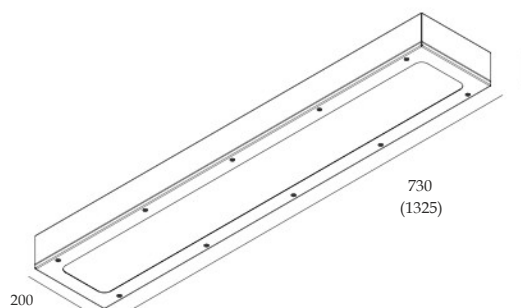
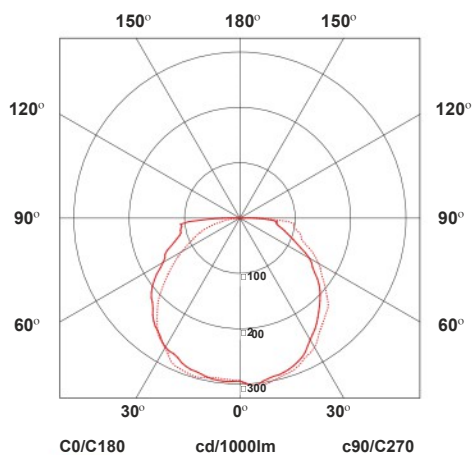

Luminaire Wattage	Luminaire Output (Lumens)	Colour Temperature	Efficacy lm/W	Ra (CRI)	Reference Code
730mm format					
22W (400mA)	1 800	4000K	82	>85	LLC-HLK-22W-2R6
28W (500mA)	2 160	4000K	77	>85	LLC-HLK-28W-2R6
34W (600mA)	2 450	4000K	72	>85	LLC-HLK-34W-2R6
1325mm format					
43W (400mA)	3 770	4000K	88	>85	LLC-HLK-43W-2R12
55W (500mA)	4 700	4000K	86	>85	LLC-HLK-55W-2R12
68W (600mA)	5 600	4000K	82	>85	LLC-HLK-68W-2R12



Consult SA (PTY) LTD

