



Introducing the STRIKER-S



The **STRIKER-S** is a decorative, stylish, surface or suspended LED luminaire with a wide range of light distribution, length format and output options for retail, storage and industrial applications.



Consult SA (PTY) LTD



SABS
ISO 9001

STRIKER-S



Product Benefits

- Low maintenance
- SABS approved control gear
- SANS-IEC 60598 safety compliance and mark

Product Features

- Highly efficient modular optics with a wide range of light distribution options
- Low glare
- Variable output possible by setting different drive currents
- Options include DALI dimming, LI-Connect Bluetooth mesh control, tuneable white, emergency and sensor including Organic Response sensor
- Life L₈₀ B₁₀ - 50 000 hours
- Driver life F₁₀ - 100 000 hours
- Supply = 220-240V 50-60Hz PF>0.95
- Ripple (flicker) < 5%
- 5 year guarantee

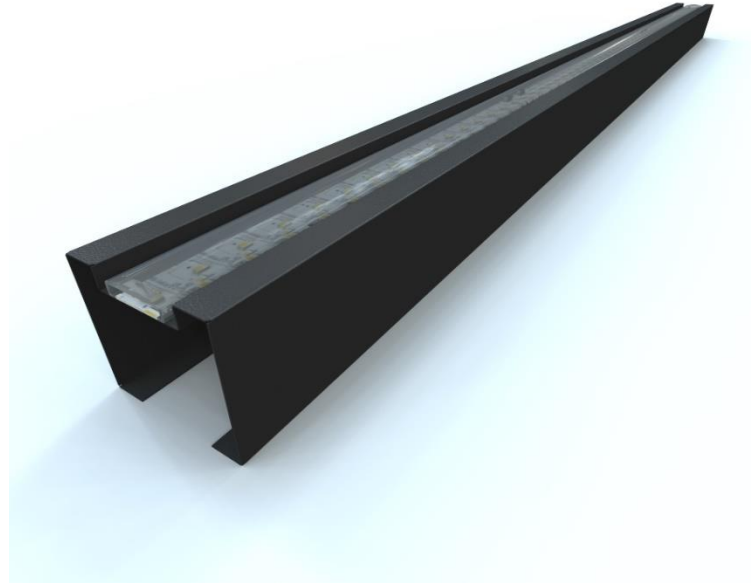

Retail Symmetric

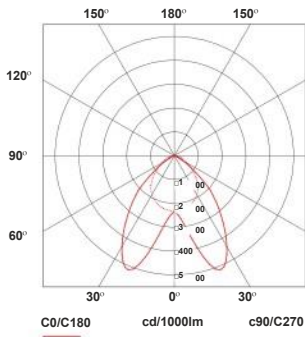

Retail Asymmetric

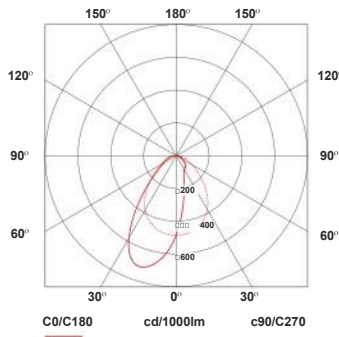

126 lm/W

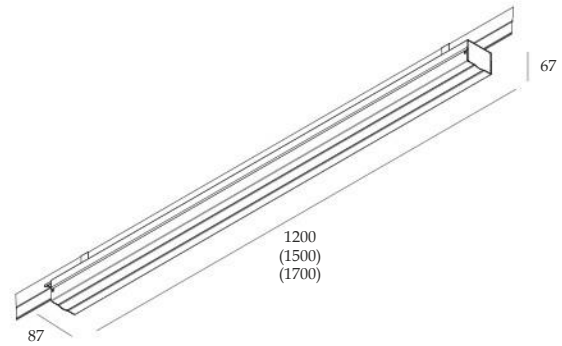

Available in various light distribution options including Retail Symmetric, Retail Asymmetric, Batwing, Wide 60, Wide 90 and High Rack (Oval)

Efficacy Rating

- PREMIUM RANGE** >140 lm/W
- MID RANGE** 120 - 140 lm/W
- ECO RANGE** 100 - 120 lm/W

Luminaire Wattage	Luminaire Output (Lumens)	Colour Temperature	Efficacy lm/W	Ra (CRI)	Reference Code
1120mm Module					
27W (350mA)	3 400	4000K	126	>80	LLC-STK-S-27W-1R12
35W (450mA)	4 300	4000K	123	>80	LLC-STK-S-35W-1R12
42W (550mA)	5 040	4000K	120	>80	LLC-STK-S-42W-1R12
55W (700mA)	6 220	4000K	113	>80	LLC-STK-S-55W-1R12
1500mm Module					
41W (350mA)	5 200	4000K	126	>80	LLC-STK-S-41W-1R15
52W (450mA)	6 400	4000K	123	>80	LLC-STK-S-52W-1R15
64W (550mA)	7 700	4000K	120	>80	LLC-STK-S-64W-1R15
82W (700mA)	9 300	4000K	113	>80	LLC-STK-S-82W-1R15
1700mm Module					
41W (350mA)	5 200	4000K	126	>80	LLC-STK-S-41W-1R17
52W (450mA)	6 400	4000K	123	>80	LLC-STK-S-52W-1R17
64W (550mA)	7 700	4000K	120	>80	LLC-STK-S-64W-1R17
82W (700mA)	9 300	4000K	113	>80	LLC-STK-S-82W-1R17



Consult SA (PTY) LTD

